

# ARTROMOT<sup>®</sup>-S2 *PRO*



## **Service Manual**

Starting from Serial Number 3000

# Table of contents

1. History	2
2. Purpose	2
3. General	2
4. Packing and unpacking the ARTROMOT®-S2 PRO	4
5. Block diagram of the electronic parts	6
6. Bill of material for service parts	7
7. Special function Service menu	8
8. How to make repairs	9
9. Checklist of safety and function test	16

## 1. History

Revision	Date	Name	Change
1	01.06.2003	S. Herr	Service Manual created
2	05.04.2004	S. Herr	Update Pos. 13, function test

## 2. Purpose

The purpose of this Service Manual is to help you make simple repairs on the ARTROMOT®-S2 PRO. Only authorized staff may perform repairs and maintenance as the manufacturer's warranty and liability would otherwise be invalidated.

Only original parts may be used for servicing in accordance with the attached spare parts list.

## 3. General

### 3.1 Electronics, connection cables

- **No** plugs may be connected or disconnected while the unit is switched on. Always switch the ARTROMOT®-S2 PRO off before connecting or disconnecting a plug.
- The locks for the motor element assembly and the spiral cable for the hand-held programming unit have to be closed at all times.
- Only original chip cards may be used. Insert the chip cards so that ARTROMOT® is visible.
- Possible errors: The following errors can be displayed on the hand-held programming unit:

Chipcard not readable: The chipcard was not readable or it contains invalid data

-> Try to format the chipcard

-> Use new chipcard if not effective

-> Replace Hand-held programming unit (0.0034.072) if not effective

Chipcard K2 PRO: Chipcard of knee CPM K2 PRO was inserted

-> Use chipcard for the shoulder CPM

-> or format the chipcard

-> or use new chipcard

Chipcard unknown: A foreign or defectice chipcard was inserted

-> Use new chipcard

Chipcard missing: No chipcard is inserted

-> Insert chipcard

Chipcard not writable: The chipcard is not writable

-> Use new chipcard

-> Replace Hand-held programming unit (0.0034.072) if not effective

Error motor X Calibration: The calibration data for the motor X is invalid or lost.

-> Motor X needs to be calibrated

Error motor X Potentiometer: Potentiometer reading was invalid

-> Replace motor element assembly (0.0034.030)

Error motor X Pot. Contact: Potentiometer connection is broken

-> Replace motor element assembly (0.0034.030)

Error motor X Motor driver: The motor driver IC reported an error

-> Replace motor element assembly (0.0034.030)

Error motor X Motor error: The motor did not turn properly  
-> Replace motor element assembly (0.0034.030)

Error motor X Over current: The current for motor X exceeded the maximum limit  
-> Replace motor element assembly (0.0034.030)

Error motor X Motor control: Internal error in motor control of motor X  
-> Replace motor element assembly (0.0034.030)

Error motor X CPM ROM error: Memory error in motor control of motor X  
-> Replace motor element assembly (0.0034.030)

Error motor X Communication: Communication to motor X not possible  
-> Check spiral cables and connectors  
-> Replace motor element assembly (0.0034.030) if not effective

Error motor X CPM device error: General error in motor control of motor X  
-> Replace motor element assembly (0.0034.030)

Error motor X Enable timeout: Motor X could not be enabled in time  
-> Replace motor element assembly (0.0034.030)

Error motor X Inval. Parameter: Motor control X has received an invalid parameter from the handheld prog. Unit  
-> Replace motor element assembly (0.0034.030)  
-> Replace Hand-held programming unit (0.0034.072) if not effective

Error motor X Mot. Release: The motor could not be released  
-> Replace motor element assembly (0.0034.030)  
-> Replace Hand-held programming unit (0.0034.072) if not effective

Error motor X Stop unexpected: The motor X stopped unexpectedly  
-> Check spiral cables and connectors  
-> Replace motor element assembly (0.0034.030)

Error motor X Motor disabled: The motor control X disabled the motor  
-> Replace motor element assembly (0.0034.030)

Error motor X ROM exceeded: Motor X moved beyond the programmed range of motion  
-> Replace motor element assembly (0.0034.030)

Error motor X CPM 5 V supply: 5 V supply of motor control X not sufficient  
-> Replace motor element assembly (0.0034.030)

Error motor X CPM 24 V supply: 24 V supply of motor control X not sufficient  
-> Replace motor element assembly (0.0034.030)

Error motor X Enable error: The motor X could not be enabled  
-> Replace motor element assembly (0.0034.030)

Error motor X Disable timeout: The motor X could not be disabled  
-> Replace motor element assembly (0.0034.030)

Error motor X Internal com.: Invalid interchip communication inside motor X  
-> Replace motor element assembly (0.0034.030)

Error Motor X Unknown CPM err.: Unknown error in motor control X  
-> Replace motor element assembly (0.0034.030)

Error Motor X Undefined err.: Undefined error in motor control X

-> Replace motor element assembly (0.0034.030)

Handset error H.Set ROM error: Memory error in the Hand-held programming unit  
-> Replace Hand-held programming unit (0.0034.072) if not effective

Handset error HS 24 V supply: 24 V supply of the Hand-held programming unit not sufficient  
-> Replace electronic S2 *PRO* complete (0.0034.251)  
-> Replace Hand-held programming unit (0.0034.072) if not effective

Handset error HS 5 V supply: 5 V supply of the Hand-held programming unit not sufficient  
-> Replace Hand-held programming unit (0.0034.072)

Handset error HS 3.3 V supply: 3.3 V supply of the Hand-held programming unit not sufficient  
-> Replace Hand-held programming unit (0.0034.072)

Handset Error Internal com.: Invalid interchip communication inside the Hand-held prog. Unit  
-> Replace Hand-held programming unit (0.0034.072)

Handset error Bus error: System bus error  
-> Replace motor element assembly (0.0034.030)  
-> Replace Hand-held programming unit (0.0034.072) if not effective  
-> Replace electronic S2 *PRO* complete (0.0034.251) if not effective

Parameter not valid: Internal error in the Hand-held programming unit  
-> Replace Hand-held programming unit (0.0034.072)

Configuration not valid: Invalid configuration of the Hand-held programming unit  
-> Replace Hand-held programming unit (0.0034.072)

Wrong product combination: Mixup between non compatible chair and Hand-held programming unit  
-> Use correct Hand-held programming unit

Chair Memory error: Defective memory chip inside the chair  
-> Replace electronic S2 *PRO* complete (0.0034.251)

### 3.2 Motor element assembly

- **No** plugs may be connected or disconnected while the unit is switched on. Always switch the ARTROMOT®-S2 *PRO* off before connecting or disconnecting a plug.
- The motor element assembly plugs have to be locked at all times.
- The movable screws should not be completely unscrewed when adjustments are being made. Make sure that the movable screws are tightened for operation and transport.
- Make sure that no load is on the profile when making adjustments on the upper arm. To remove the load, slightly lift the B motor.

### 3.3 Other

- The scale profiles with the labeling 2, 3 and 5 must not be lubricated or oiled.
- No solvents may be used when cleaning the ARTROMOT®-S2 *PRO*.

## 4. Packing and unpacking the ARTROMOT®-S2 PRO

Preparations for transport of the ARTROMOT®-S2 PRO are as follows. The first step is to place the device in factory setting. See Cap. 7.2.

Next, disconnect the plug of the mobility element assembly and pull out the armrest and mobility element assembly.

Both parts are to be transported separately.

Set ante/retroversion to 0 degrees adjustment and push the backrest fully forward after opening the wing screw on the backrest.

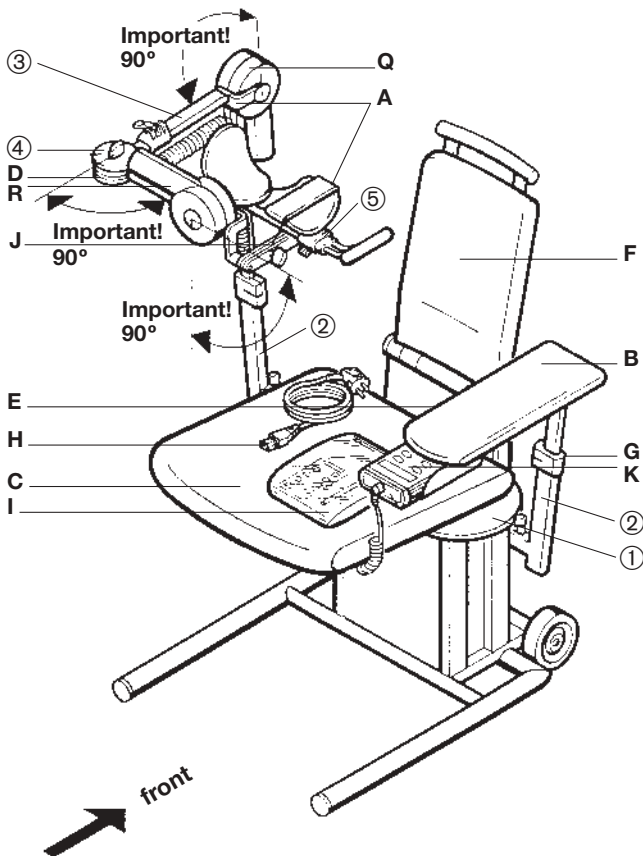

- |                                     |                         |
|-------------------------------------|-------------------------|
| A motor element complete            | ① scale 1 (blue number) |
| B armrest for healthy arm           | ② scale 2 (blue number) |
| C seat                              | ③ scale 3 (blue number) |
| D elbow joint                       | ④ scale 4 (blue number) |
| E screw for adjustment of back rest | ⑤ scale 5 (blue number) |
| F back rest                         |                         |
| G screw for height adjustment       |                         |
| H power cord                        |                         |
| I transparent packing               |                         |
| J lower arm rest                    |                         |
| K hand-held programming unit        |                         |
| Q motor A                           |                         |
| R motor B                           |                         |

Wedge the hand-held programming unit between the backrest and the seat.

For transportation, use only the original packing box. Ormed GmbH & Co. KG does not guarantee against damage from transport in cases where the original packing box is not used.

### A Prepare device for packaging

**Attention:** Device has to be moved in "Factory Settings"

Please follow the instruction step by step!

Prepare device like "Picture A"!

- Standing in front of the device the motor element (A) must be on the left side. In case that motor element (A) is on the right hand side follow the instructions to convert it to the left hand side. Hold motor element (A) in one hand and open the screw (G) with the other hand. Then draw motor element (A) out and convert it to the left side. Close screw (G).
- Standing in front of the device the arm rest (B) must be on the right side.
- Put hand controller (K) on seat (C).
- Adjust motor element (A) scale 3 (blue number) on smallest (1) point.
- Adjust elbow joint (D) scale 4 (blue number) on >> 90° R <<.
- Adjust motor element (A) scale 5 (blue number) on smallest (1) point.
 

**Attention:** Standing in front of the device lower arm rest (J) must be behind motor B (R) and has to be positioned horizontal! Important!
- Adjust scale 1 (blue number) on 0° - both sides
- Open screw (E) to turn down back rest (F). Close screw.
- Open screw (G) and draw out armrest (B).
- Open screw (G) and draw out motor element (A).
- Turn down at the back side of the device the black security bow and draw the plug (O) out.

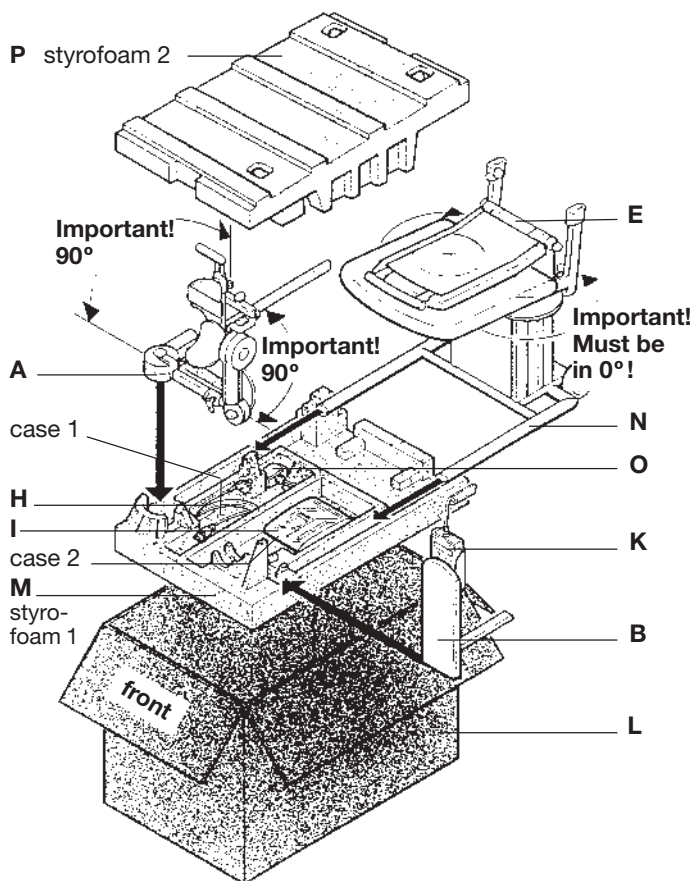

## B Device packaging

1. Position the carton (L) on the ground.
2. Insert styrofoam 1 (M) into the carton.
3. Place power cord (H) in case 1.
4. Place transparent packing (I) (including manual, pen, ORMED box) in case 2.
5. Place chair (N) in carton.
6. Place motor element (A) and plug (O) in case 1
7. Place arm rest (B).
8. Insert hand-held programming unit (K) in case of arm rest (B).
9. Put styrofoam 2 (P) on the top.

- |  |                                     |
|--|-------------------------------------|
| <b>A</b> motor element complete            | <b>K</b> hand-held programming unit |
| <b>B</b> armrest for healthy arm           | <b>L</b> carton                     |
| <b>C</b> seat                              | <b>M</b> styrofoam 1                |
| <b>D</b> elbow joint                       | <b>N</b> chair                      |
| <b>E</b> screw for adjustment of back rest | <b>O</b> plug for motor element     |
| <b>F</b> back rest                         | <b>P</b> styrofoam 2                |
| <b>G</b> screw for height adjustment       |                                     |
| <b>H</b> power cord                        |                                     |
| <b>I</b> transparent packing               |                                     |
| <b>J</b> lower arm rest                    |                                     |

➔ moving direction

## 5. Block diagram of the electronic parts

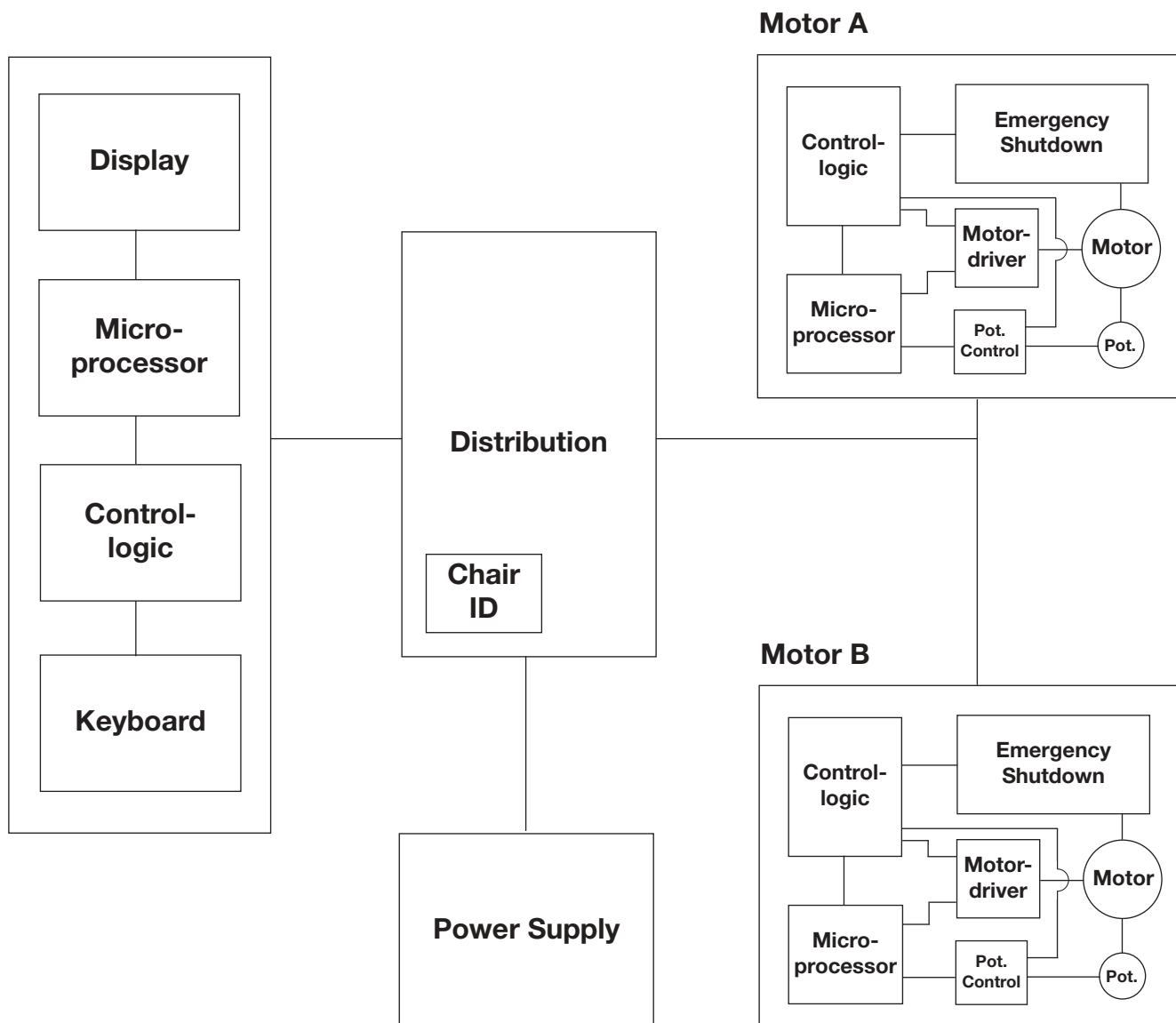

## 6. Bill of material for service parts

Position	Description	Order number
1	Electronic S2 <i>PRO</i> complete	0.0034.251
2	Power supply	0.0034.244
3	Hand-held programming unit S2 <i>PRO</i> with spiral cable	0.0034.072
4	Armrest assembly	2.0034.022
5	Motor element assembly	0.0034.030
6	Armrest cup complete	0.0034.190
7	Belt loop	2.0003.001
8	Upholstered elbow cup	2.0034.255
9	Lever assembly	0.0034.012
10	Wing nut elbow joint	GN532-40-M8-E
11	Wing nut swing bar	GN532-40-M8-E
12	Wing screw backrest	2.0034.044
13	Clamping piece exchange kit up to S/N 3386	0.0034.060
13	Clamping piece exchange kit starting from S/N 3387	0.0034.059
14	Scale left	2.0034.342
15	Scale right	2.0034.343
16	Upholstered seat	2.0034.007
17	Upholstered backrest S2 <i>PRO</i>	2.0034.016
18	Wheel assembly	0.0034.006
19	Tube cap	0.0034.123
20	Sticker Motor A Artromot	2.0034.267
21	Sticker Motor B Artromot	2.0034.271
22	Base of chair	0.0034.121
23	Chipcard box	0.0034.047
24	Chipcard ARTROMOT	0.0034.048
25	Fuse T 1,0A	0.0000.005
26	Power cord, US version	0.0034.011
27	Power cord, EU version	0.0034.118

## 7. Special function Service menu

Service menu:

- Device runtime
- Factory settings
- Error log
- Calibration

Entering the service menu:

- Switch to the programming mode
- Press "FUNC"
- Select **Service menu** using the "+" and "-" keys
- Press "SET" for 5 seconds  
**For service only** is flashing
- Select a special function by using "+" and "-" keys

### 7.1 Device runtime

- Display: **Device runtime**
- Press "SET"
- The display shows the device runtime of each motor  
Display: **A: X h B: X h**

### 7.2 Factory settings (= Packaging setting)

- Display: **Factory settings**
- Press "SET"
- Display: **Werkseinstellung bereit**
- Device changes language
- Press "STOP"
- Display: **Bereich anfahren START drücken**
- Press "START", the device moves to factory settings
- Display: **STOP Dauerbetrieb**

### 7.3 Error log

- Display: **Error log**
- Press "SET"
- Display: **Error log Up + Down -**
- By using the "+" and "-" keys you can see the entries of the error log  
(the highest number is the last entry)

### 7.4 Calibration

How to perform a calibration:

- Display: **Calibration**
- Press "SET"
- Display: **Enter key**
- Press "+" and "-" keys simultaneously
- Display: **Select motor With +/- ==> A**
- Press "SET", Display: **Move Mot A to 90 Press SET**
- Move Motor A to 90° by using "+" and "-" keys
- Press "SET", Display: **Calibrating M. A Please wait**  
Motor A moves in the complete range of motion automatically
- After Motor A stops the display shows: **Calibration M. A successful**
- Press "STOP"
- Display: **Select motor With +/- ==> B**
- Press "+", Display: **Select motor With +/- ==> B**
- Press "SET", Display: **Move Mot B to 0 Press SET**
- Move Motor B to 0° by using "+" and "-" keys
- Press "SET", Display: **Calibrating M. B Please wait**  
Motor B moves in the complete range of motion automatically
- After Motor B stops the display shows: **Calibration M. B successful**
- Press "STOP" two times
- Display: **Move to ROM Press START**

## 8. How to make repairs



### Position 1 Electronic S2 PRO complete

Switch off the ARTROMOT®-S2 PRO.

First, the plugs for the power supply, the motor plug for the motor element assembly, and the plug on the hand-held programming unit's spiral cable have to be disconnected. Then remove the top 4 screws from the metal plate and slightly lift the whole power supply with the metal plate. Now, the plug connection for the ground wire has to be disconnected separately.

Once the spare part has been installed, a functional and safety test has to be conducted; see the checklist attached.



### Position 2 Power supply

When installing electronic components, make sure that the generally applicable ESD (Electro-Static Discharge) guidelines are upheld.

Remove the whole Power supply, including the metal plate and the plug-in connectors, from the ARTROMOT®-S2 PRO as shown in Position 1.

Unplug the connectors from the Power supply and unscrew the 4 screws holding the Power supply to the metal plate.

Once the spare part has been installed, a functional and safety test has to be conducted; see the checklist attached.



### Position 3 Hand-held programming unit S2Pro with spiral cable

Switch off the ARTROMOT®-S2 PRO.

Now, the plug on the hand-held programming unit's spiral cable can be disconnected and the new plug connected.



### Position 4 Armrest assembly

First, unscrew the wing screw (see Position 13) on the clamping piece. Now, the armrest can be exchanged.



**Position 5** Motor element assembly

Switch off the ARTROMOT®-S2 PRO. Now open the locks of the motor plugs, disconnect the connecting piece, and unscrew the wing screw on the clamping piece. Now, the whole motor element assembly can be exchanged. Once the new motion unit has been inserted, the motor element assembly plugs must be relocked.



**Position 7** Belt loop

Pull the belt out through the metal loop, exchange the belt loop, and install the new belt loop.



**Position 6** Armrest cup complete

Unscrew both screws and remove the armrest cup. Screw the new armrest cup onto the bar using the rubber washers and countersunk screws.



**Position 8** Upholstered elbow cup

First, the defective cushion has to be removed carefully so that the new cushion can be attached once the inside of the elbow cup has been cleaned.



**Position 9** Lever assembly

Remove one of the side retaining rings and pull out the pin so that the defective lever can be taken out. When using the new lever, make sure that both springs are properly set. The retaining rings then have to be put onto both sides of the pin.  
The complete lever assembly has to be regularly serviced.



**Position 11** Wing nut swing bar

Make sure that the new wing nut is tight.



**Position 10** Wing nut elbow joint

Lift motor B so that there is no load on the thread when tightening the wing nut.



**Position 12** Wing screw backrest

Make sure that the new wing screw is tight.  
Warning: Wing screws must not be interchanged.



**Position 13** Clamping piece exchange kit

The exchange kit of clamping pieces contains 2 clamping pieces (1 left and 1 right) with all of the required screws and exact instructions for installation. The clamping pieces have to be serviced regularly.



**Position 15** Scale right

First, remove the cushion. See the instructions for Position 16. Once the 3 screws have been unscrewed, the scale can be exchanged.



**Position 14** Scale left

First, remove the cushion. See the instructions for Position 16. Once the 3 screws have been unscrewed, the scale can be exchanged.



**Position 16** Upholstered seat

The 4 screws under the seat cushion first have to be removed. Now the seat cushion can be easily exchanged. Make sure that the 4 screws underneath are tightened again.



**Position 17** Upholstered backrest *S2 PRO*

First, unscrew all 9 screws on the rear plate. Remove the rear plate so the backrest can be unscrewed. Now, screw the handle onto the new backrest and predrill the 9 holes to fasten the rear panel to fit the rear plate. (3 mm drill, some 10 mm deep). Now, the backrest and then the rear plate can be screwed on again.



**Position 19** Tube cap

The tube cap should be glued in if possible.



**Position 18** Wheel assembly

Once the screw has been unscrewed, the roll can be easily exchanged.



**Position 20** Sticker Motor A Artromot

Stick on the sticker "A" as shown in the Figure.



**Position 21** Sticker Motor B Artromot

Stick on the sticker "B" as shown in the Figure.

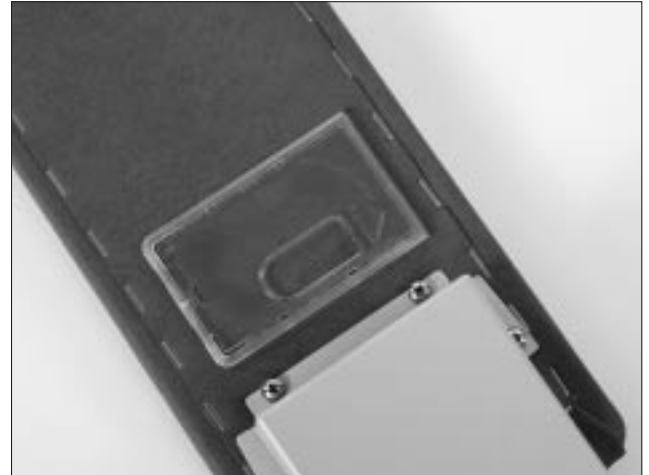

**Position 23** Chipcard box

The chip card box is attached to the underside of the armrest. Use any usual commercial plastic adhesive for this purpose.



**Position 22** Base of chair

The base of the chair is assembled under the chair. Unscrew the 2 screws so the base can be easily replaced.



**Position 24** Chipcard Artromot

Only original chip cards may be used. Insert the chip cards so that ARTROMOT® is visible.



**Position 25** Fuse

Switch the ARTROMOT®- S2 *PRO* off and pull the mains plug.

Disconnect the fuse holder on the power input and plug it back into the plate after the fuses have been exchanged. Only use the appropriate fuses.

## 9. Checklist of safety and function test

Safety test	Measured value	Date/signature
Protective earth conductor resistance $\leq 0.1$ ohms	ohms	
Ground leakage current EN60601/IEC 601/VDE 0751 $\leq 500$ $\mu$ A	$\mu$ A	
<b>Or</b>		
Ground leakage current as in UL2601 $\leq 300$ $\mu$ A	$\mu$ A	

Function test	OK	Error
<p>1. Switch on the ARTROMOT®- S2 PRO and press "SET".</p> <p>→ Display: Software version V1.X XX.XX.XX (X = optional)</p> <p>Press "SET" for 5 seconds</p> <p>→ Display: ARTROMOT®- S2 PRO Standard</p>		
<p>2. The motion range for ab/adduction (motor A) is 30 to 175 degrees.</p> <p>→ At 90 degrees, the angle is to be checked with a tolerance of +/- 4 degrees.</p>		
<p>3. The motion range for rotation (motor B) is from -90 to +90 degrees.</p> <p>→ At 0 degrees, the angle is to be checked with a tolerance of +/- 4 degrees.</p>		
<p>4. Check the emergency-off function.</p> <p>Switch the ARTROMOT®- S2 PRO on in continuous operation.</p> <p>→ Press any key to stop motors A and B immediately.</p> <p>Check this for all keys.</p>		
<p>5. Press "ab/adduction" and STOP simultaneously to switch to the programming mode.</p> <p>→ Display: "Adduction" as well as the present and the programmed angles.</p>		
<p>6. Press "FUNC". Press "+" to change to the special function "new patient" and press "SET".</p> <p>-&gt; Display: "New Patient ready"</p> <p>Now press "STOP"</p> <p>-&gt; Display: "Move to Rom Press Start"</p> <p>Press "START"</p> <p>→ The ARTROMOT®- S2 PRO moves into center position.</p>		
<p>7. Check the set values. Press the following keys to do so.</p> <p>"Ab/Adduktion" → Display: ADD 89 90 ABD 91</p> <p>"Rotation" → Display: INT -1 0 EXT 1</p> <p>"Pause" → Display: ADD/I.ROT 0 S, ABD/E.ROT 0 S</p> <p>"Motors ON/OFF" → Display: M.A ADD/ABD ON M.B ROTAT ON</p> <p>"Speed" → Display: Speed 100% = 230°/min</p> <p>"Timer" → Display: Timer Continuous</p>		



DIN EN 13485



ORMED Nr.018 829-01

Ormed GmbH & Co. KG • Merzhauser Straße 112 • D-79100 Freiburg  
Phone +49 761 4566-01 • Fax +49 761 4566-5501 • [www.ormed.de](http://www.ormed.de) • E-Mail: [info@ormed.de](mailto:info@ormed.de)  
St. Paul/USA, Phone +1 800 4402784, Fax +1 651 4157405 • Prague/CR, Phone +420 2 84094650,  
Fax +420 2 84094660 • Vienna/A, Tel +43 1 53 20 83 40, Fax +43 1 53 20 83 431

